

Ersatzteilliste
Spare parts list
Lista di ricambi



Gläserespülautomat
Glasswashing machine
Lavabicchieri

EcoStar 545 D



EcoStar 545 D

Inhaltsverzeichnis:	Contents:	Indice:	Seite/ Page/ Pagina
01.02 Waschpumpe	Wash pump	Pompa di lavaggio	4
02.05 Pumpenansaugung	Pump suctioning	Aspirazione pompa	5
03.25 Wasch- und Nachspülsystem	Washing and rinsing system	Sistema di lavaggio e risciacquo	6
04.08 Magnetventil	Solenoid valve	Elettrovalvola	8
05.01 Rücksaugeverhinderer	Reflux preventor	Dispositivo di non ritorno	9
06.08 Niveauregelung	Level control	Regolazione di livello	10
08.25 Einbauboiler	Incorporated boiler	Boiler incorporato	11
09.05 Tankheizung	Tank heating	Riscaldamento della vasca	13
10.07 Klarspülerdosierung	Rinse aid dosing unit	Dosatore del brillantante	14
11.41 Elektroniksteuerung	Electronic control	Comando elettronico	16
12.10 Elektroteile	Electrical parts	Ricambi elettrici	17
13.13 Baugruppen/Einzelteile	Component blocks/Parts	Blocchi di componenti / pezzi	19
14.08 Haubengestänge	Hood rod	Maniglione della cappa	20
16.01 Einbauwasserenthärter	Incorporated softener	Addolcitore incorporato	22
17.05 Reinigerdosierung	Detergent dosing unit	Dosatore del detergente	24

KENNZEICHNUNG DER ERSATZTEILE

* / V DIESE TEILE EMPFEHLEN WIR AUF LAGER ZU LEGEN!
 V VERSCHLEISSTEIL!

ÄNDERUNGEN IN AUSFÜHRUNG UND KONSTRUKTION VORBEHALTEN.

SPECIAL MARKS OF SPARES

WE RECOMMEND TO STORE THESE PARTS!
 WEAR AND TARE PART!

WE RESERVE THE RIGHT TO CHANGE EXECUTION AND CONSTRUCTION.

MARCATURA SPECIALE DEI RICAMBI

RACCOMANDIAMO DI AVERE IN DEPOSITO QUESTI RICAMBI!
 RICAMBI D'USURA!

CI RISERVIAMO I DIRITTI DI APPORTARE MODIFICHE D'ESECUZIONE E DI COSTRUZIONE.

MEIKO Maschinenbau GmbH & Co.
 Englerstraße 3
 D-77652 Offenburg
 Telefon: 0781 / 203 - 0
 Telefax: 0781 / 203 - 1179
 www.meiko.de
 e-mail: info@meiko.de

01.02 WASCHPUMPE

01.02 WASH PUMP

01.02 POMPA DI LAVAGGIO

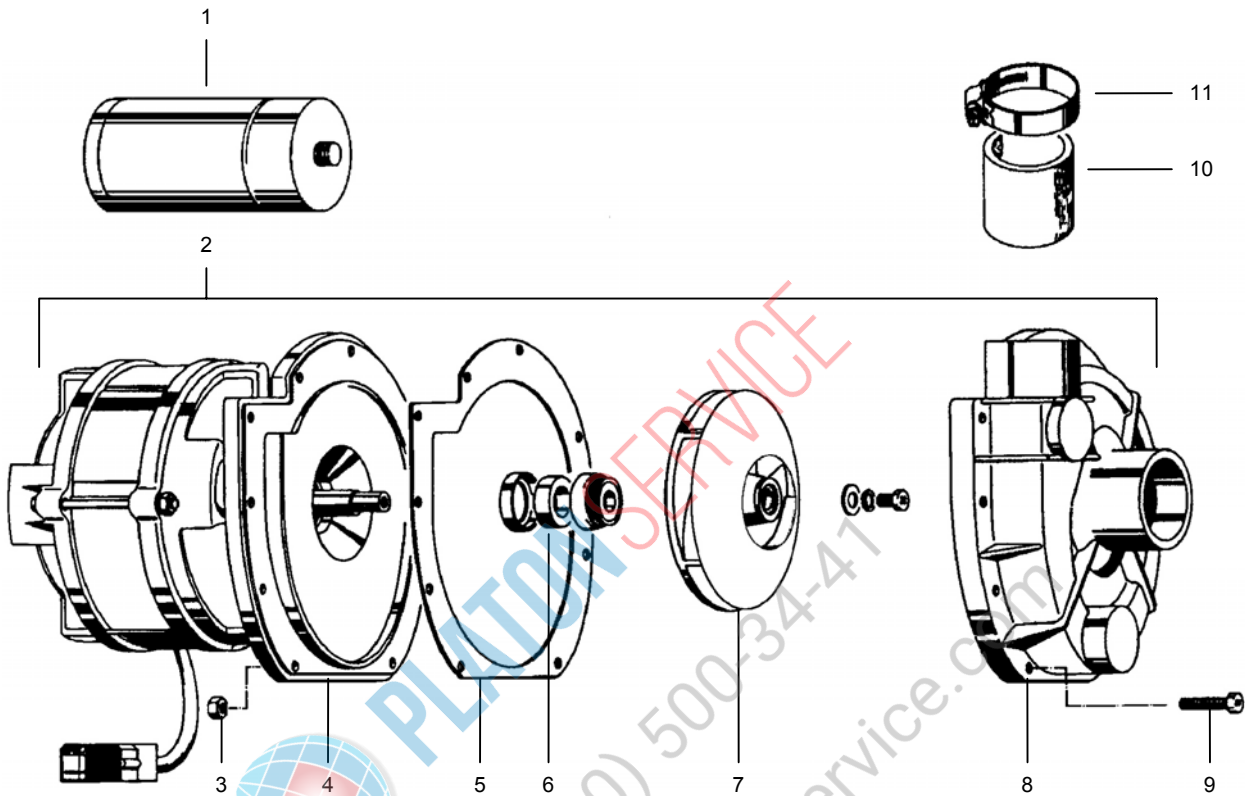

POS	IDENT. NR. IDENT. NO.	BEZEICHNUNG	DESIGNATION	DESCRIZIONE
1	* 9606122	KONDENSATOR 20 µF	CONDENSER 20 µF	CONDENSATORE 20 µF
2	* 9604594	PUMPE PU 0,7/2256, 0,75 KW 180-253V 50HZ	PUMP PU 0,7/2256, 0,75 KW 180-253V 50HZ	POMPA PU 0,7/2256, 0,75 KW 180-253V 50HZ
3	0335005	SECHSKANTMUTTER DIN 934 M 4	HEXAGON NUT DIN 934 M 4	DADO ESAGONALE DIN 934 M 4
4	0501105	LAGERSCHILD MIT PUMPEN- DECKEL	END SHIELD WITH PUMP LID	FLANGIA FINALE CON COPERCHIO POMPA
5	* 0501094	PUMPENGEHÄUSEDICHTUNG	PACKING FOR PUMP HOUSING	GUARNIZIONE CORPO POMPA
6	V 0501095	GLEITRINGDICHTUNG KPL.	SLIDING SEAL COMPL.	ANELLO TENUTA COMPL.
7	* 9537022	PUMPENLAUFRAD	PUMP WHEEL	GIRANTE
8	0501091	PUMPENGEHÄUSE	PUMP HOUSING	CORPO POMPA
9	0303015	SECHSKANTSCHRAUBE DIN 933 M 4 X 25	HEXAGON SCREW DIN 933 M 4 X 25	VITE ESAGONALE DIN 933 M 4 X 25
10	0640007	SCHLAUCH SCHWARZ DIN 904 - Ø38 X 4	HOSE BLACK DIN 904 - Ø38 X 4	FLESSIBILE NERO DIN 904 - Ø38 X 4
11	0233046	SCHLAUCHKLEMME 32 - 50	HOSE CLAMP 32 - 50	COLLARE 32 - 50
	0467004	TYPENSCHILD (NICHT GEZEICHNET)	LABEL (NOT DESIGNED)	TARGHETTA (NON DISEGNATA)
	8004160	MOTORKONSOLE	MOTOR CONSOLE	CONSOLE DEL MOTORE

02.05 PUMPENANSAUGUNG

02.05 PUMP SUCTIONING

02.05 ASPIRAZIONE POMPA



Pu01_02c.doc
01.12.2000/FH

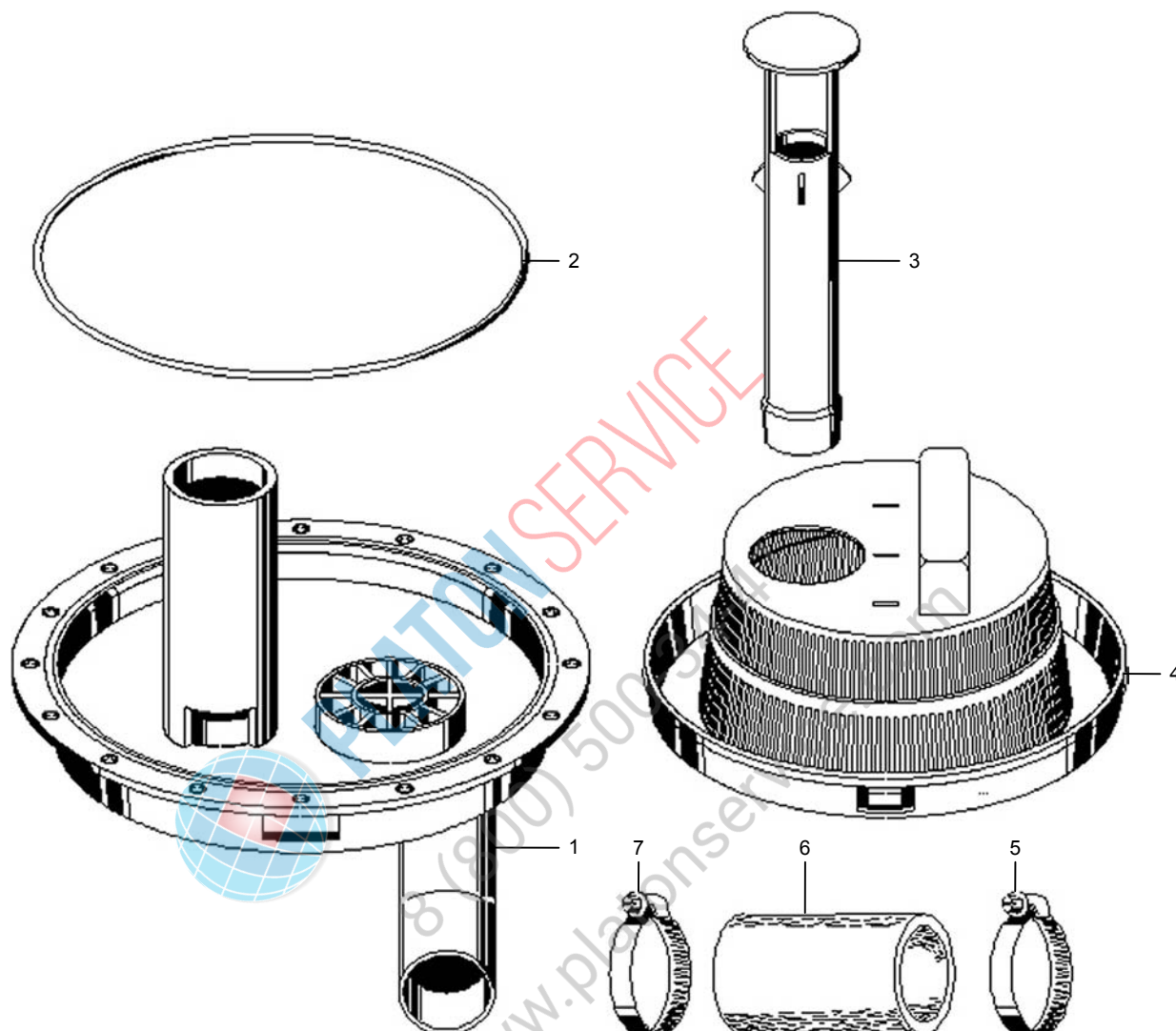

POS	IDENT. NR. IDENT. NO.	BEZEICHNUNG	DESIGNATION	DESCRIZIONE
1	9628526	PUMPENSUMPF DV 40/80 T(FA) / ECOSTAR 545D	PUMP SUMP DV 40/80 T(FA) / ECOSTAR 545D	VASCHETTA POMPA CON TROPPOPIENO DV 40/80 T(FA) / ECOSTAR 545D
2	* 0401061	O-RING 206,5 X 3,53	O-RING 206,5 X 3,53	ANELLO O-RING 206,5 X 3,53
3	0620457	STANDROHR 255 LANG, K 413	STAND PIPE 255 LONG, K 413	TROPPOPIENO 255 LUNGO, K 413
4	0620346	SIEB MIT SCHMUTZRINNE K 337	FILTER WITH DIRT TRAP K 337	FILTRO CON CANALETTA RESIDUI K 337
5	0233041	SCHLAUCHKLEMME 40 - 60	HOSE CLAMP 40 - 60	COLLARE 40 - 60
6	8002454	SCHLAUCH GLASKLAR Ø35 X 5 X 70	HOSE TRANSPARENT Ø35 X 5 X 70	FLESSIBILE TRASPARENTE Ø35 X 5 X 70
7	0233046	SCHLAUCHKLEMME 32 - 50	HOSE CLAMP 32 - 50	COLLARE 32 - 50

03.25 WASCH- UND NACHSPÜLSYSTEM

03.25 WASHING AND RINSING SYSTEM

03.25 SISTEMA DI LAVAGGIO E RISCIAQUO



Wn3_19.doc
07.02.2002/BP

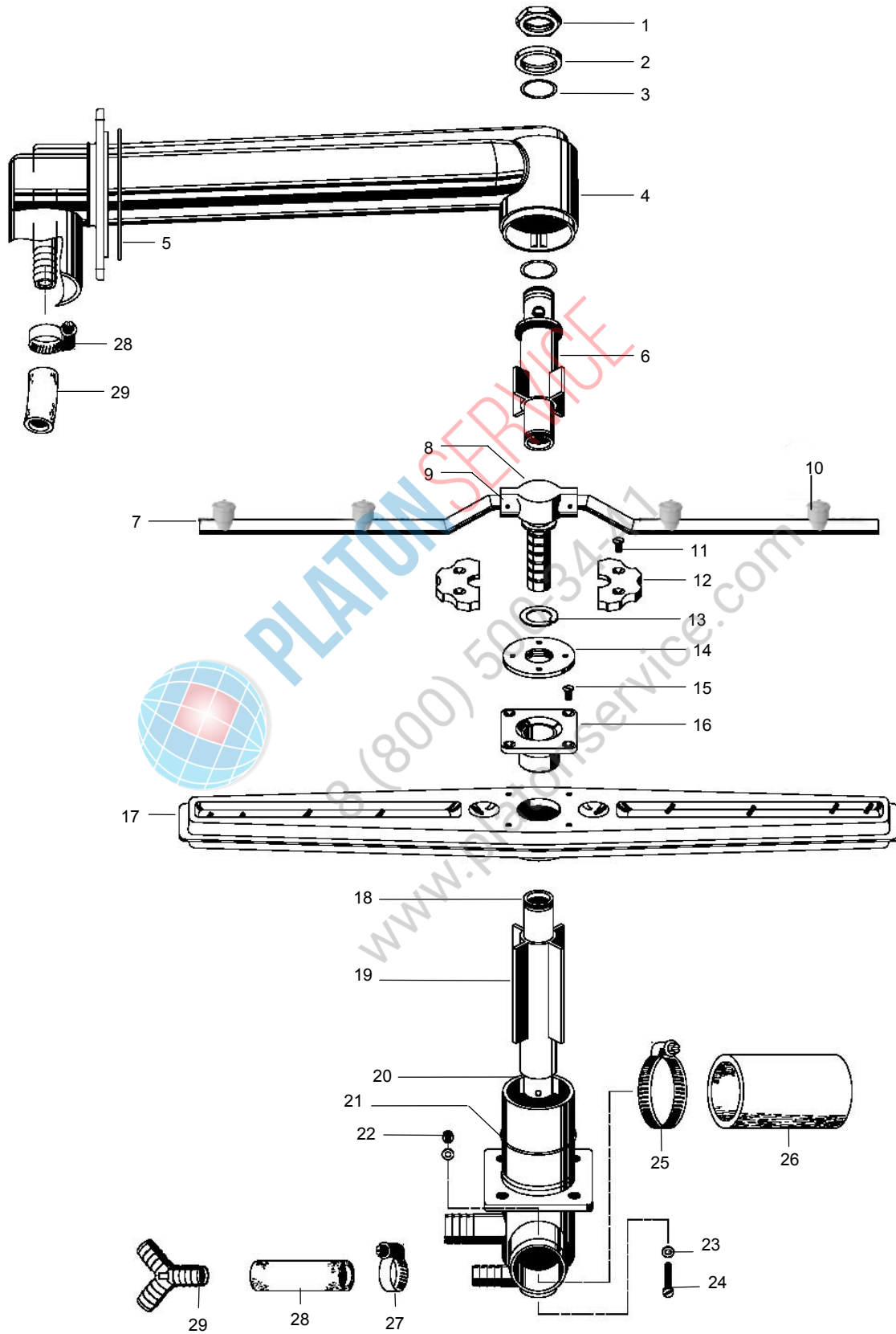

03.25 WASCH- UND NACHSPÜLSYSTEM

03.25 WASHING AND RINSING SYSTEM

03.25 SISTEMA DI LAVAGGIO E RISCIAQUO



Wn3_19.doc
07.02.2002/BP

POS	IDENT. NR. IDENT. NO.	BEZEICHNUNG	DESIGNATION	DESCRIZIONE
1	9550206	VERSCHLUSSKAPPE	CLOSING CAP	CAPPUCCIO DI CHIUSURA
2	8004468	DISTANZSCHEIBE	SPACER	RONDELLA DISTANZIATORE
3	0401016	O-RING 21 X 2	O-RING 21 X 2	ANELLO O-RING 21 X 2
4	8004454	STEIGROHR KPL. DV 80 T	ASCENDING PIPE COMPL. DV 80 T	CANALE DI DISTRIBUZIONE COMPL. DV 80 T
4	8004481	STEIGROHR KPL. DV 120 T	ASCENDING PIPE COMPL. DV 120 T	CANALE DI DISTRIBUZIONE COMPL. DV 120 T
5	0401065	O-RING 84 X 2	O-RING 84 X 2	ANELLO O-RING 84 X 2
6	0620506	BEFESTIGUNGSROHR OBEN KPL.	UPPER FIXING TUBE COMPL.	TUBO DI FISSAGGIO SUP. COMPL.
7	9542558	NACHSPÜLDREHARM OBEN BAUGRUPPE	UPPER ROTATING RINSE ARM BLOCK	BRACCIO DI RISCIAQUO SUPERIORE, BLOCCO
7	9542559	NACHSPÜLDREHARM UNTEN BAUGRUPPE	LOWER ROTATING RINSE ARM BLOCK	BRACCIO DI RISCIAQUO INFERIORE, BLOCCO
8	* 8002880	LAGERZAPFEN K 242	BEARING BOLT K 242	PERNO K 242
9	0354000	KERBSTIFT DIN 1473 2 X 20	GROOVED PIN DIN 1473 2 X 20	COPIGLIA DIN 1473, 2 X 20
10	* 9517406	NACHSPÜLDÜSE KPL.	RINSE NOZZLE CPL.	UGELLO RISCIAQUO CLP.
11	0306005	SENKSCRAUBE DIN 963 M4 X 6	FLAT HEAD SCREW DIN 963 M4 X 6	VITE CON TESTA CONICA DIN 963 M4 X 6
12	0620211	SCHEIBENHÄLFTE K 211	HALF DISK K 211	MEZZO ANELLO K 211
13	* 0403303	TEFLONRING 17 X 26 X 1	TEFLON RING 17 X 26 X 1	ANELLO TEFLON 17 X 26 X 1
14	8000049	MUTTER OBEN LINKSGEWINDE	UPPER NUT LEFT-HAND THREAD	DADO SUPERIORE FILETTATURA A SINISTRA
14	8000048	MUTTER UNTEN RECHTSGEWINDE	LOWER NUT RIGHT-HAND THREAD	DADO INFERIORE FILETTATURA A DESTRA
15	0306006	SENKSCRAUBE DIN 963 M4 X 8	FLAT HEAD SCREW DIN 963 M4 X 8	VITE CON TESTA CONICA DIN 963 M4 X 8
16	* 0620282	DREHARMNABE OBEN	UPPER ROTATING ARM HUB	MOZZO SUPERIORE PER BRACCIO ROTANTE
16	* 0620281	DREHARMNABE UNTEN	LOWER ROTATING ARM HUB	MOZZO INFERIORE PER BRACCIO ROTANTE
17	8000147	WASCHARM OBEN, BAUGRUPPE	UPPER WASH ARM, BLOCK	BRACCIO DI LAVAGGIO SUPERIORE, BLOCCO
17	8000146	WASCHARM UNTEN, BAUGRUPPE	LOWER WASH ARM, BLOCK	BRACCIO DI LAVAGGIO INFERIORE, BLOCCO
X	8004451	DREHARMLAGER UNTEN BAUGRUPPE	LOWER ROTATING ARM BEARING BLOCK	CUSCINETTO INFERIORE BRACCIO ROTANTE, BLOCCO
18	8000174	BEFESTIGUNGSROHR UNTEN	LOWER FIXING TUBE	TUBO DI FISSAGGIO INFERIORE
19	0620233	ZENTRIERSTERN K 233	CENTERING DEVICE STAR K 233	STELLA DI CENTRAGGIO K 233
20	0620443	DREHARMLAGER K 396	ROTATING ARM BEARING K 396	CUSCINETTO BRACCIO ROTANTE K 396
21	* 0401030	O-RING 50 X 1,5	O-RING 50 X 1,5	ANELLO O-RING 50 X 1,5
22	0336001	HUTMUTTER DIN 1587 - M 4	CAP NUT DIN 1587 - M 4	DADO A CAPPELLO DIN 1587 - M 4
23	0409000	DICHTUNG 4 X 8 X 1	PACKING 4 X 8 X 1	GUARNIZIONE 4 X 8 X 1
24	0308030	ZYLINDERSCHRAUBE DIN 84 M4 X 40	PAN HEAD SCREW DIN 84 M4 X 40	VITE CON TESTA CILINDRICA DIN 84 M4 X 40
25	0233046	SCHLAUCHKLEMME 32 - 50	HOSE CLAMP 32 - 50	COLLARE 32 - 50
26	8002454	SCHLAUCH KLARSICHT Ø35 X 5 X 70	TRANSPARENT HOSE Ø35 X 5 X 70	FLESSIBILE TRASPARENTE Ø35 X 5 X 70
27	0233043	SCHLAUCHKLEMME 12 - 22	HOSE CLAMP 12 - 22	COLLARE 12 - 22
28	0640012	SCHLAUCH GRAU 1/2"	HOSE GREY 1/2"	FLESSIBILE GRIGIO 1/2"
29	* 0621036	Y-STÜCK YS 13	Y-PIECE YS 13	RACCORDO A FORMA Y - YS 13

04.08 MAGNETVENTIL

04.08 SOLENOID VALVE

04.08 ELETTRIVALVOLA



EcoStar645 D
15.10.98/PT

Optional für Niederlande / optional for Netherlands / opzione per i paesi bassi



POS	IDENT. NR. IDENT. NO.	BEZEICHNUNG	DESIGNATION	DESCRIZIONE
1	0113098	MAGNETVENTILFILTERSIEB	FILTER SIEVE F. SOLENOID VALVE	FILTRO PER ELETTRIVALVOLA
2	9506227	MENGENREGLER 17 L/ MIN.	QUANTITY REGULATOR 17 L/MIN	REGOLATORE DI QUANTITÀ 17 L/MIN
3	* 9505869	MAGNETVENTIL NW 10 GERADE AUSFÜHRUNG ECOSTAR 530 F / 545 D	SOLENOID VALVE NW 10 LINEAR EXECUTION ECOSTAR 530 F / 545 D	ELETTRIVALVOLA NW 10, ESECUZIONE LINÉARE ECOSTAR 530 F / 545 D
4	* 9541819	MAGNETVENTIL NW 10 ECKAUSFÜHRUNG ECOSTAR 430 F	SOLENOID VALVE NW 10 ANGLED EXECUTION ECOSTAR 430 F	ELETTRIVALVOLA NW 10, ESECUZIONE AD ANGOLO ECOSTAR 430 F
5	* 0233043	SCHLAUCHKLEMME 12 - 22	HOSE CLAMP 12 - 22	COLLARE 12 - 22
6	* 0640012	SCHLAUCH GRAU 1/2"	HOSE GREY 1/2"	FLESSIBILE GRIGIO 1/2"
7	0621035	T-STÜCK TS 13	T-PIECE TS 13	RACCORDO A T TS 13
8	9500454	OPTIONAL FÜR NIEDERLANDE RÜCKSCHLAGVENTIL 3/4"A X 3/4"l	OPTIONAL FOR NETHERLANDS CHECK VALVE 3/4"A X 3/4"l	OPZIONE PER PAESI BASSI VALVOLA DI NON RITORNO ¾"AX¾"l

05.01 RÜCKSAUGEVERHINDERER

05.01 REFLUX PREVENTOR

05.01 DISPOSITIVO DI NON RITORNO

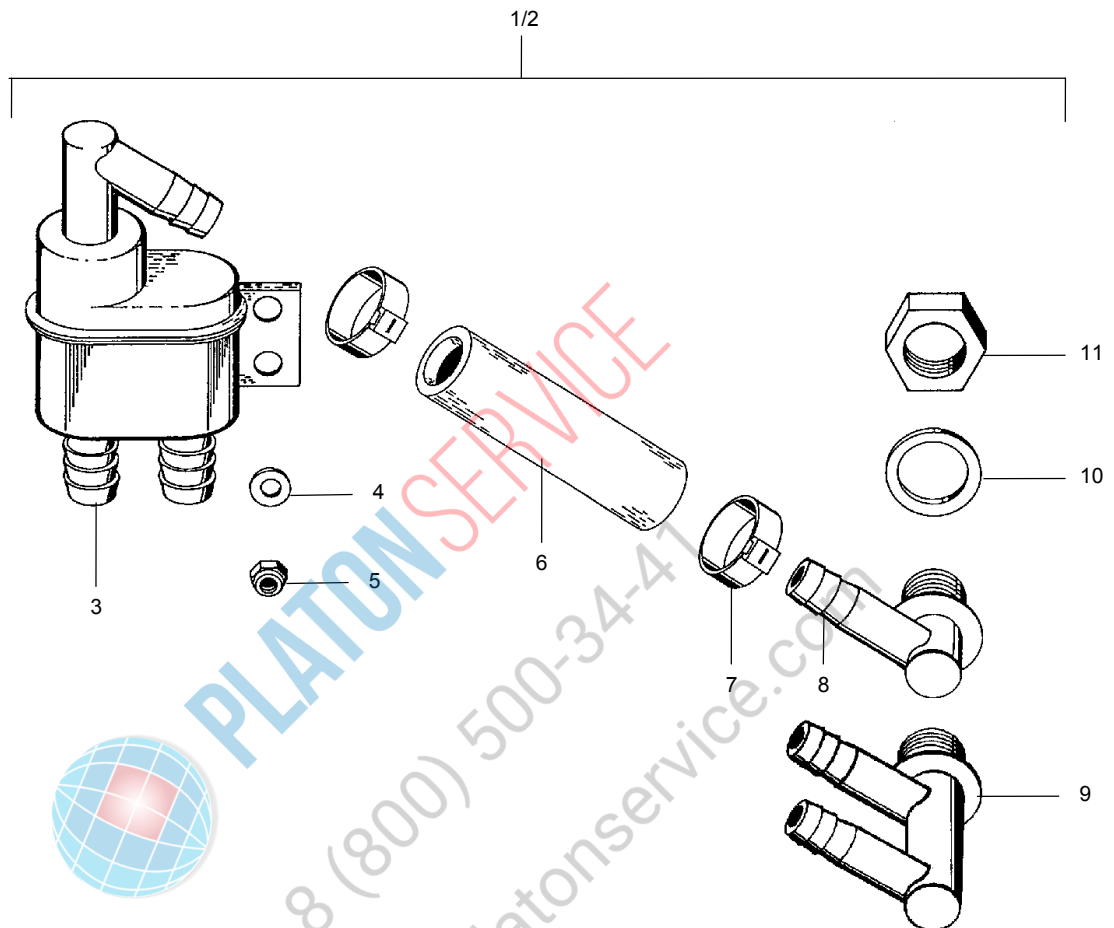

POS	IDENT. NR. IDENT. NO.	BEZEICHNUNG	DESIGNATION	DESCRIZIONE
1	8002731	RÜCKSAUGEVERHINDERER 1/2" KPL. (OHNE EW)	REFLUX PREVENTOR 1/2" COMPL. (WITHOUT EW)	DISPOSITIVO DI NON RITORNO 1/2" COMPL. (SENZA EW)
2	8002732	RÜCKSAUGEVERHINDERER 1/2" KPL. (MIT EW)	REFLUX PREVENTOR 1/2" COMPL. (WITH EW)	DISPOSITIVO DI NON RITORNO 1/2" COMPL. (CON EW)
3	* 0620334	RÜCKSAUGEVERHINDERER K 333	REFLUX PREVENTOR K 333	DISPOSITIVO DI NON RITORNO K 333
4	0340027	UNTERLEGSCHIEBE DIN 522 - 5,8 X 11 X 1	WASHER DIN 522 - 5,8 X 11 X 1	RONDELLA DIN 522 - 5,8 X 11 X 1
5	0337001	SECHSKANTMUTTER SELBST- SICHERND DIN 985 - M 5	HEXAGON NUT SELFFIXING DIN 985 - M 5	DADO DIN 985 - M 5
6	0640012	SCHLAUCH GRAU 1/2"	HOSE GREY 1/2"	FLESSIBILE GRIGIO 1/2"
7	0233070	1-OHR-KLEMME	1-EAR CLAMP	COLLARE AD UN ORECCHIO
8	* 0620342	SCHLAUCHANSCHLUSS EINFACH K 340	HOSE CONNECTION SIMPLE K 340	COLLEGAMENTO FLESSIBILE SEMPLICE K 340
9	* 0620343	SCHLAUCHANSCHLUSS DOPPELT K 341 (MIT EW)	HOSE CONNECTION DOUBLE K 340 (WITH EW)	COLLEGAMENTO FLESSIBILE DOPPIO K 340 (CON EW)
10	* 0217433	GUMMIDICHTUNG 17 X 24 X 2	RUBBER PACKING 17 X 24 X 2	GUARNIZIONE IN GOMMA 17X24X2
11	0360211	SECHSKANTMUTTER R 3/8" X 5	HEXAGON NUT R 3/8" X 5	DADO R 3/8" X 5

06.08 NIVEAUREGELUNG

06.08 LEVEL CONTROL

06.08 REGOLAZIONE DI LIVELLO



EcoStar645 D
01.07.2002/FUS

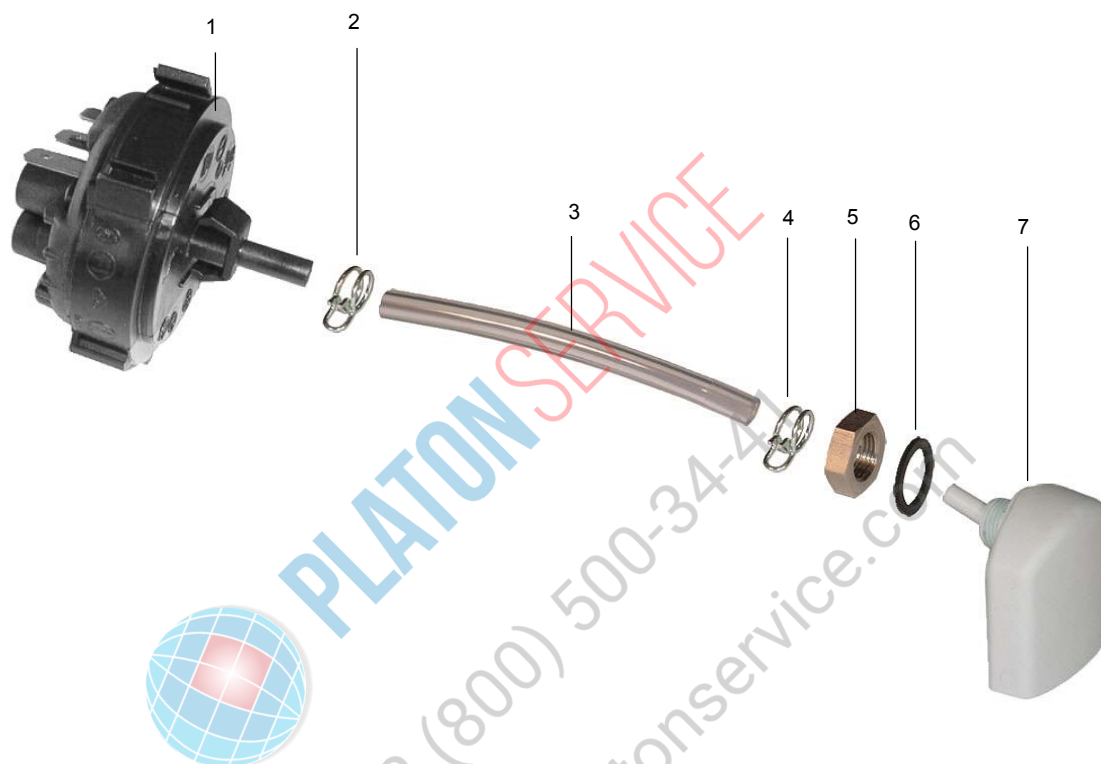

POS	IDENT. NR. IDENT. NO.	BEZEICHNUNG	DESIGNATION	DESCRIZIONE
1	* 0130027	DRUCKSENSOR 90/25	LEVEL SWITCH 90/25	REGOLAZIONE DI LIVELLO 90/25
2	* 9500044	SCHLAUCHKLEMME SILBER	HOSE WIRE CLAMP SILVER	COLLARE
1	* 0260006	SCHLAUCH KLARSICHT Ø5	HOSE TRANSPARENT Ø5	FLESSIBILE TRASPARENTE 5 X 1,5
2	* 9500045	SCHLAUCHKLEMME GELB	HOSE WIRE CLAMP YELLOW	COLLARE GIALLO
3	9515957	MUTTER 3/8"	NUT 3/8"	DADO 3/8"
4	* 9515964	DICHTUNG	PACKING	GUARNIZIONE
5	* 9515955	LUFTFALLE	AIR TRAP	CAMERA COMPRESSIONE ARIA

08.25 EINBAUBOILER

08.25 INCORPORATED BOILER

08.25 BOILER INCORPORATO



BH8_25.doc
01.12.2000/Fh

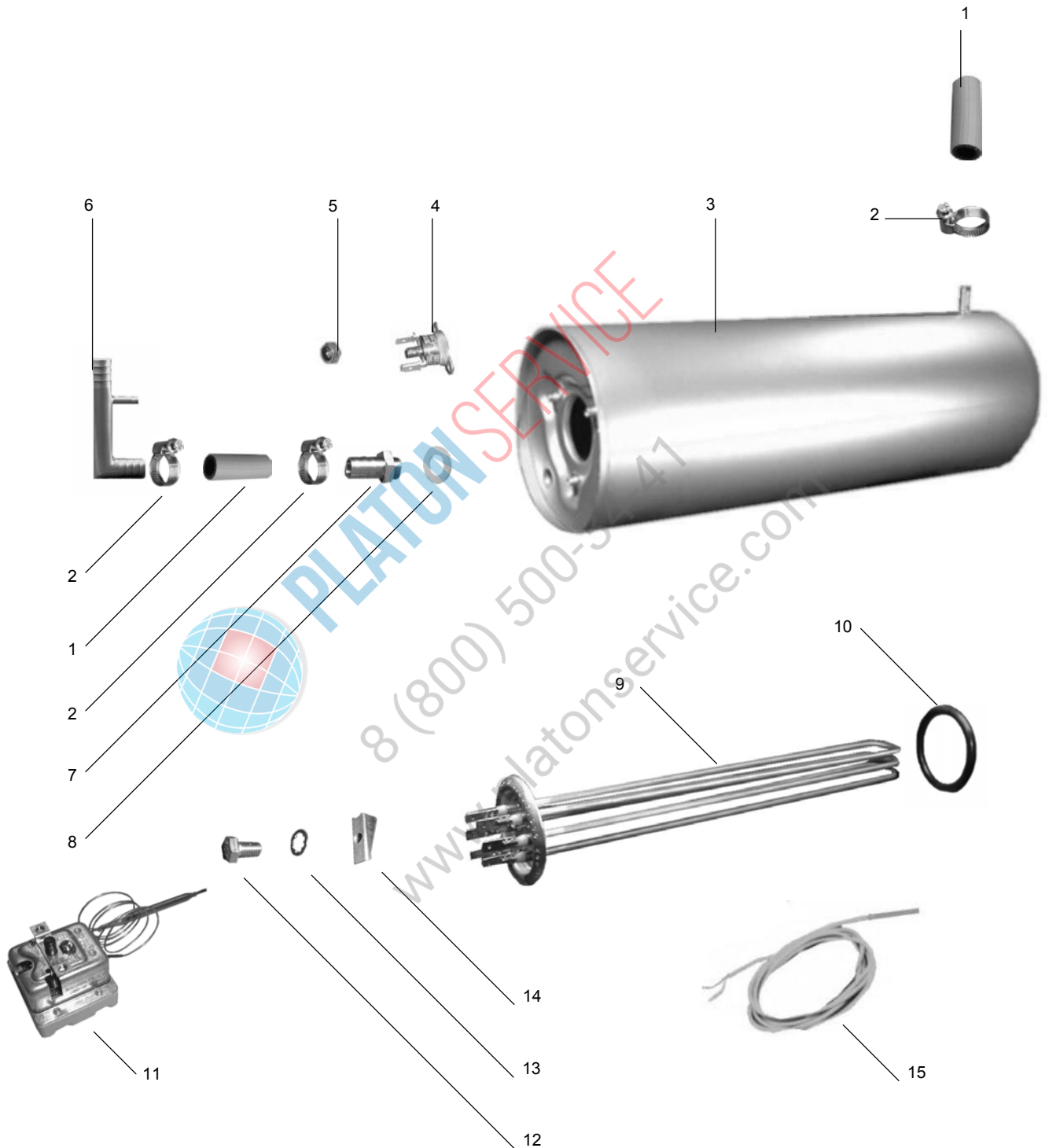

08.25 EINBAUBOILER

08.25 INCORPORATED BOILER

08.25 BOILER INCORPORATO



BH8_25.doc
01.12.200/Fh

POS	IDENT. NR. IDENT. NO.	BEZEICHNUNG	DESIGNATION	DESCRIZIONE
1	* 0640012	SCHLAUCH GRAU 1/2"	HOSE GREY 1/2"	FLESSIBILE GRIGIO 1/2"
2	* 0233037	SCHLAUCHKLEMME 16 - 27	HOSE CLAMP 16 - 27	COLLARE 16 - 27
3	8400269	EINBAUBOILERGEHÄUSE ABGEPRESST	BOILER HOUSING TESTED UNDER PRESSURE	CARCASSA BOILER COLLAUDATO SOTTO PRESSIONE
4	* 0108038	TEMPERATURBEGRENZER 105 GRAD, 1 KONTAKT	TEMPERATURE LIMITER 105 DEGREES, 1 CONTACT	LIMITATORE DI TEMPERATURA 105 GRADI, 1 CONTATTO
5	0335000	SECHSKANTMUTTER DIN 934 - M 3	HEXAGON NUT DIN 934 - M 3	DADO ESAGONALE DIN 934 - M 3
6	0620373	SCHLAUCHANSCHLUSSWINKEL K 368	HOSE CONNECTION ANGLE K 368	ANGOLO COLLEGAMENTO FLESSIBILE K 368
7	0360202	SCHLAUCHANSCHLUSS	HOSE CONNECTION	COLLEGAMENTO FLESSIBILE
8	* 0408008	DICHTUNG 25 X 14 X 1,5	PACKING 25 X 14 X 1,5	GUARNIZIONE 25 X 14 X 1,5
9	* 9504228	TOPFFLANSCHHEIZKÖRPER 3 KW, 230/400 V	FLANGE HEATING ELEMENT 3 KW, 230/400 V	RESISTENZA A FLANGIA 3 KW, 230/400 V
	* 9504234	TOPFFLANSCHHEIZKÖRPER 4,5 KW, 230/400 V	FLANGE HEATING ELEMENT 4,5 KW, 230/400 V	RESISTENZA A FLANGIA 4,5 KW, 230/400 V
	* 9504236	TOPFFLANSCHHEIZKÖRPER 6 KW, 230/400 V	FLANGE HEATING ELEMENT 6 KW, 230/400 V	RESISTENZA A FLANGIA 6 KW, 230/400 V
	* 9504237	TOPFFLANSCHHEIZKÖRPER 7,5 KW, 230/400 V	FLANGE HEATING ELEMENT 7,5 KW, 230/400 V	RESISTENZA A FLANGIA 7,5 KW, 230/400 V
	* 9504240	TOPFFLANSCHHEIZKÖRPER 9 KW, 230/400 V	FLANGE HEATING ELEMENT 9 KW, 230/400 V	RESISTENZA A FLANGIA 9 KW, 230/400 V
	* 9500498	TOPFFLANSCHHEIZKÖRPER 12 KW, 230/400 V	FLANGE HEATING ELEMENT 12 KW, 230/400 V	RESISTENZA A FLANGIA 12 KW, 230/400 V
10	* 0101176	HEIZKÖRPERDICHTUNG 58 X 45 X 6	PACKING F. HEATING ELEMENT 58 X 45 X 6	GUARNIZIONE DI RESISTENZA 58 X 45 X 6
11	* 9502526	TEMPERATURBEGRENZER 120 GRAD, 3 KONTAKTE	TEMPERATURE LIMITER 120 DEGREES, 3 CONTACTS	LIMITATORE DI TEMPERATURA 120 GRAD, 3 KONTAKTE
12	0302048	SECHSKANTSCHRAUBE DIN 933 - M 5 X 8	HEXAGON SCREW DIN 933 - M 5 X 8	VITE ESAGONALE DIN 933 - M 5 X 8
13	0342010	ZAHNSCHEIBE DIN 6797 - J 5,3	TOOTH LOCK WASHER DIN 6797 - J 5,3	RONDELLA DENTATA DIN 6797 - J 5,3
14	0101183	SPANNBRÜCKE	GRIPPING YOKE	PONTE DI TENSIONE
15	* 9500236	TEMPERATURFÜHLER Ø 6X50 SI	TEMPERATURE PROBE Ø 6X50 SI	SONDA DI TEMPERATURA Ø 6X50 SI
	8400259	EINBAUBOILER KPL. 3 KW	INCORPORATED BOILER COMPL. 3 KW	BOILER INCORPORATO COMPL. 3 KW
	8400260	EINBAUBOILER KPL. 6 KW	INCORPORATED BOILER COMPL. 6 KW	BOILER INCORPORATO COMPL. 6 KW
	8400261	EINBAUBOILER KPL. 7,5 KW	INCORPORATED BOILER COMPL. 7,5 KW	BOILER INCORPORATO COMPL. 7,5 KW
	8400229	EINBAUBOILER KPL. 9 KW	INCORPORATED BOILER COMPL. 9 KW	BOILER INCORPORATO COMPL. 9 KW

09.05 TANKHEIZUNG

09.05 TANK HEATING

09.05 RISCALDAMENTO DELLA VASCA

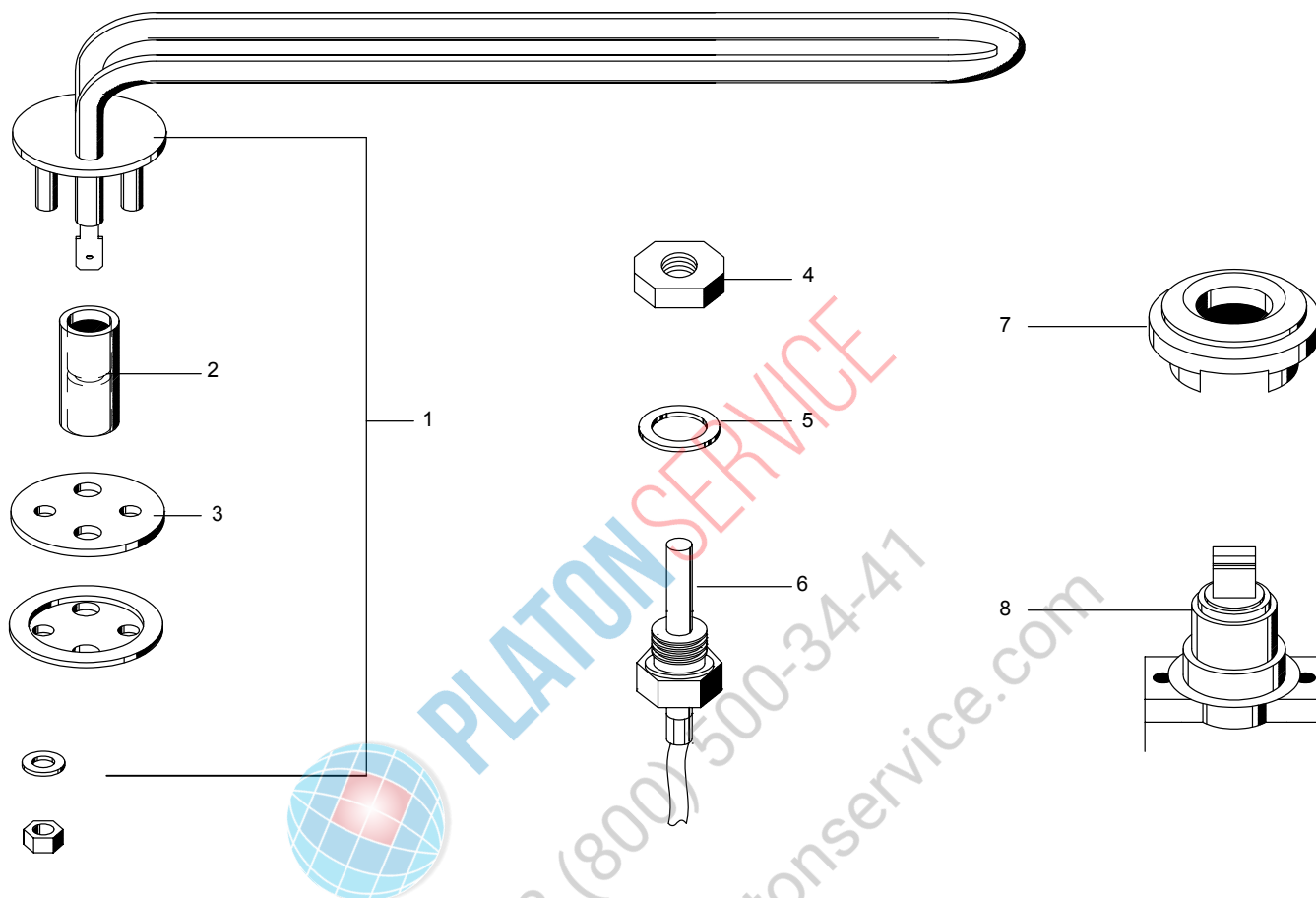

POS	IDENT. NR. IDENT. NO.	BEZEICHUNG	DESIGNATION	DESCRIZIONE
1	* 0101152	HEIZKÖRPER 2 KW, 230 V	HEATING ELEMENT 2 KW, 230 V	RESISTENZA 2 KW, 230 V
2	9543319	BERÜHRUNGSSCHUTZ	PROTECTION AGAINST CONTACT	PROTEZIONE CONTRO CONTATTO
3	* 0101175	HEIZKÖRPERDICHTUNG	HEATING ELEMENT PACKING	GUARNIZIONE PER RESISTENZA
4	* 0212012	SECHSKANTMUTTER 1.4301 DIN 431 R1/4"	HEXAGON NUT 1.4301 DIN 431 R1/4"	DADO ESAGONALE 1.4301 DIN 431 R1/4"
5	* 0408227	DICHTUNG 19 X 13	PACKING 19 X 13	GUARNIZIONE 19 X 13
6	* 0180682	TEMPERATURFÜHLER R1/4"	TEMPERATURE PROBE R1/4"	SONDA DI TEMPERATURA R1/4"
7	* 0108040	GUMMIMANSCHETTE	RUBBER PACKING	PEZZO IN GOMMA
8	* 0108043	TEMPERATURBEGRENZER	TEMPERATURE LIMITER	LIMITATORE DI TEMPERATURA

10.07 KLARSPÜLERDOSIERUNG

10.07 RINSE AID DOSING UNIT

10.07 DOSATORE DEL BRILLANTANTE



DOS10_7.doc
01.12.2000/FH

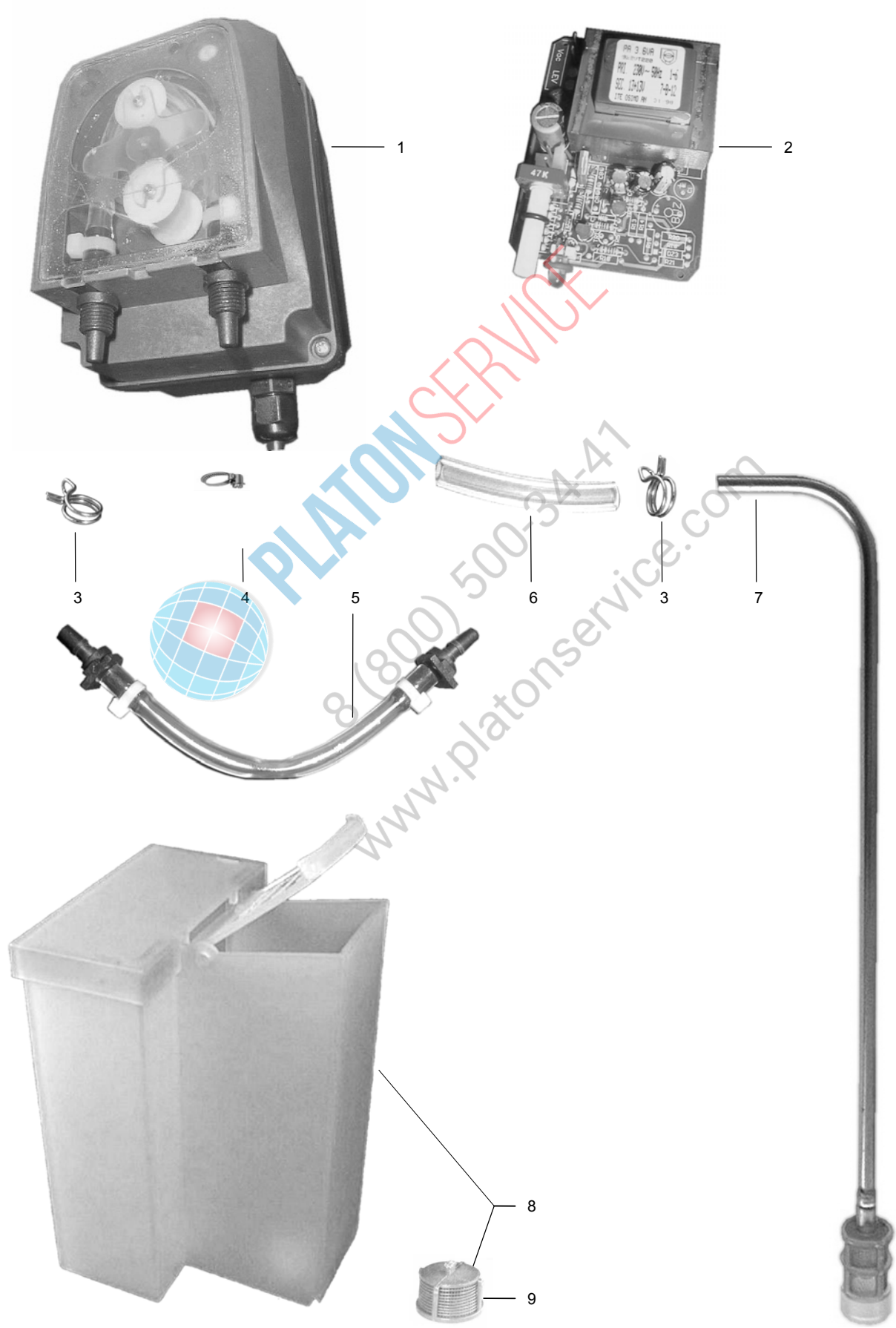

10.07 KLARSPÜLERDOSIERUNG

10.07 RINSE AID DOSING UNIT

10.07 DOSATORE DEL BRILLANTANTE



DOS10_7.doc
01.12.2000/FH

POS	IDENT. NR. IDENT. NO.	BEZEICHNUNG	DESIGNATION	DESCRIZIONE
1	* 9503331	KLARSPÜLERDOSIERGERÄT PR1, 230 V, 50 HZ	RINSE AID DOSING UNIT PR1, 230 V, 50 HZ	DOSATORE DEL BRILLANTANTE PR1, 230 V, 50 HZ
2	9505653	DREHZAHLREGELUNG	SPEED CONTROL	REGOLAZIONE GIRI
3	* 9500045	DRAHTSCHLAUCHKLEMME 8,8 - 9,3 MM	HOSE WIRE CLAMP 8,8 - 9,3 MM	COLLARE 8,8 - 9,3 MM
4	* 0233036	SCHLAUCHKLEMME 10 - 16	HOSE CLAMP 10 - 16	COLLARE 10 - 16
5	* 9505652	DOSIERSCHLAUCH 1 L/H SILIKON	DOSING HOSE 1 L/H SILICON	FLESSIBILE PER DOSARE 1 L/H SILICONE
6	V 0260007	SCHLAUCH KLARSICHT 6 X 1,5	HOSE TRANSPARENT 6 X 1,5	FLESSIBILE TRASPARENTE 6 X 1,5
6	0640017	SCHLAUCH SCHWARZ 6 X 4,5	HOSE BLACK 6 X 4,5	FLESSIBILE NERO 6 X 4,5
7	8005393	ANSAUGROHR, 340 MM	SUCTION TUBE, 340 MM	TUBO D'ASPIRAZIONE, 340 MM
7	8005372	ANSAUGROHR, 420 MM	SUCTION TUBE, 420 MM	TUBO D'ASPIRAZIONE, 420 MM
8	8003830	KLARSPÜLERBEHÄLTER K 376	RINSE AID CONTAINER K 376	CONTENITORE PER BRILLANTANTE K376
9	0113098	MAGNETVENTILFILTERSIEB	FILTER FOR SOLENOID VALVE	FILTRO PER ELETTROVALVOLA
X	9504799	RÜCKSCHLAGVENTIL	CHECK VALVE	VALVOLA DI NON RITORNO



PLATON SERVICE
8 (800) 500-34-47
www.platonservice.com

11.41 ELEKTRONIKSTEUERUNG

11.41 ELECTRONIC CONTROL

11.41 COMANDO ELETTRONICO



EcoStar645 D
07.02.02/BP

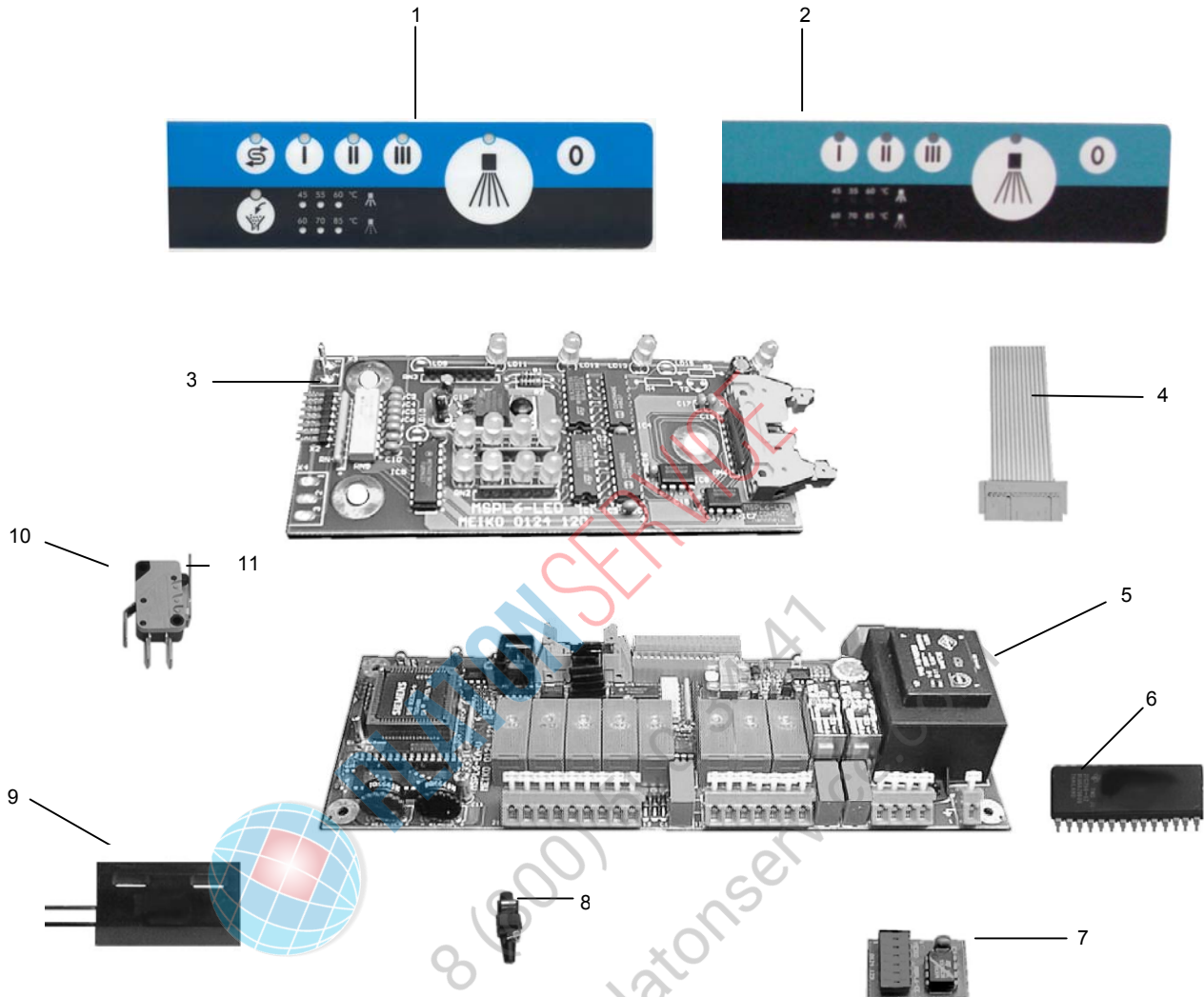

POS	IDENT. NR. IDENT. NO.	BEZEICHNUNG	DESIGNATION	DESCRIZIONE
1	9542382	FOLIENASTATUR - EW	SENSOR TOUCH PANEL - EW	TASTIERA ELETTRONICA - EW
2	* 9542402	FOLIENASTATUR	SENSOR TOUCH PANEL	TASTIERA ELETTRONICA
3	* 9532115	DIODENPLATINE MSPL6-LED	DIODE CIRCUIT BOARD	PIASTRINA DIODI MSPL6-LED
4	* 0180507	FLACHBANDKABEL M. STECKER 14 POL. 0,8 M	RIBBON CABLE WITH PLUG	CAVO PIATTO CON SPINA 14 POLI 0,8 M
5	* 9552914	STEUERPLATINE MSPL6-EA-V	CONTROL BOARD MSPL6-EA-V	PIASTRA DI COMANDO MSPL6-EA-V
6	* 0124351	EPROM MSPL6-STD	EPROM MSPL6-STD	EPROM MSPL6-STD
7	* 9534803	EEPROM MSPL6-EE NICHT PROGRAMMIERT	EEPROM MSPL6-EE NOT PROGRAMMED	EEPROM MSPL6-EE NON PROGRAMMATO
8	0175553	ABSTANDHALTER	SPREADER	DISANZIATORE
9	0122070	MAGNETSCHALTER	MAGNET SWITCH	INTERRUTTORE MAGNETICO
10	* 9544800	MICROSCHALTER	MICROSWITCH	MICRO INTERRUTTORE
11	* 0122106	HEBEL	LEVER	LEVETTA
	* 9500236	TEMPERATURFÜHLER Ø6 X 50 (BOILER)	TEMPERATURE PROBE	SONDA DI TEMPERATURA Ø6 X 50 (BOILER)
	* 0180682	TEMPERATURFÜHLER R¼"(TANK)	TEMPERATURE PROBE (TANK)	SONDA DI TEMPERATURA R¼" (VASCA)

12.10 ELEKTROTEILE

12.10 ELECTRICAL PARTS

12.10 RICAMBI ELETTRICI



Et12_10.doc
02.07.2002/BP

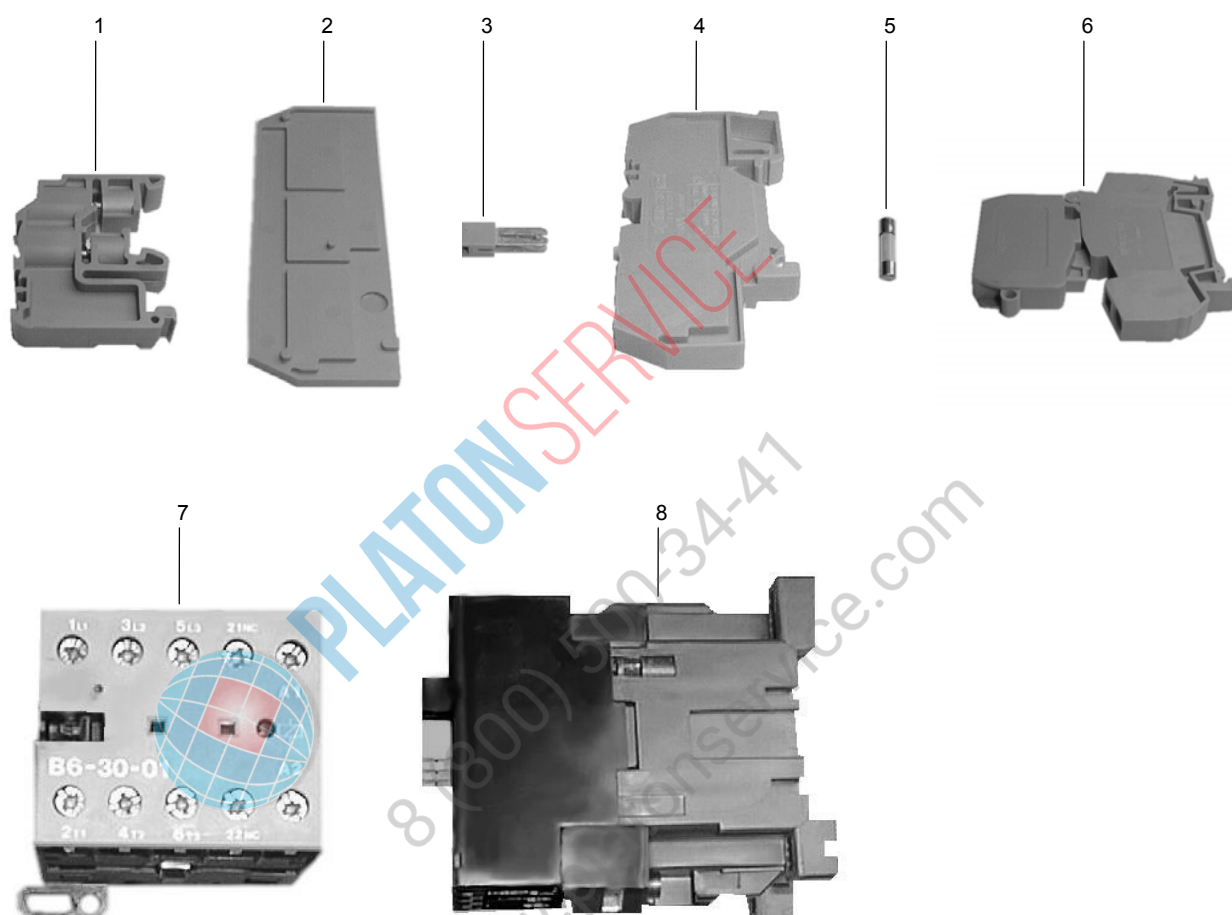

12.10 ELEKTROTEILE

12.10 ELECTRICAL PARTS

12.10 RICAMBI ELETTRICI



Et12_10.doc
02.07.2002/BP

POS	IDENT. NR. IDENT. NO.	BEZEICHNUNG	DESIGNATION	DESCRIZIONE
1	0153288	ENDHALTER	FINAL HOLDER	SUPPORTO FINALE
2	0153071	ABSCHLUß- UND ZWISCHEN- PLATTE 2,5QMM GRAU	BINDER END COVER 2,5QMM GREY	PIASTRA COPERCHIO E INTERMEDIO 2,5QMM GRIGIO
2	0153080	ABSCHLUß- UND ZWISCHEN- PLATTE 4QMM GRAU	BINDER END COVER 4QMM GREY	PIASTRA COPERCHIO E INTERMEDIO 4QMM GRIGIO
2	0153128	ABSCHLUß- UND ZWISCHEN- PLATTE 6QMM GRAU	BINDER END COVER 6QMM GREY	PIASTRA COPERCHIO E INTERMEDIO 6QMM GRIGIO
3	0153091	QUERBRÜCKER 4QMM	CROSS BRIDGE 4QMM	CONTATTO A PONTE 4QMM
3	0153126	QUERBRÜCKER 6QMM	CROSS BRIDGE 6QMM	CONTATTO A PONTE 6QMM
4	0153060	KLEMME 3-LEITER 4QMM GRAU	BINDER 3 CONDUCTORS 4QMM GREY	MORSETTIERA 3 CONDUTTORI 4QMM, GRIGIA
4	0153127	KLEMME 3-LEITER 4QMM BLAU	BINDER 3 CONDUCTORS 4QMM BLUE	MORSETTIERA 3 CONDUTTORI 4QMM, BLU
4	0153132	KLEMME 3-LEITER 4QMM GELB/GRÜN	BINDER 3 CONDUCTORS 4QMM YELLOW/GREEN	MORSETTIERA 3 CONDUTTORI 4QMM, GIALLO / VERDE
4	0153129	KLEMME 3-LEITER 6QMM GRAU	BINDER 3 CONDUCTORS 6QMM GREY	MORSETTIERA 3 CONDUTTORI 6QMM, GRIGIA
4	0153131	KLEMME 3-LEITER 6QMM BLAU	BINDER 3 CONDUCTORS 6QMM BLUE	MORSETTIERA 3 CONDUTTORI 6QMM, BLU
4	0153130	KLEMME 3-LEITER 6QMM GELB/GRÜN	BINDER 3 CONDUCTORS 6QMM YELLOW/GREEN	MORSETTIERA 3 CONDUTTORI 6QMM, GIALLO / VERDE
4	0153042	KLEMME 4-LEITER 2,5QMM GRAU	BINDER 4 CONDUCTORS 2,5QMM GREY	MORSETTIERA 4 CONDUTTORI 2,5QMM, GRIGIA
4	9505881	KLEMME 4-LEITER 2,5QMM BLAU	BINDER 4 CONDUCTORS 2,5QMM BLUE	MORSETTIERA 4 CONDUTTORI 2,5QMM BLU
4	9505882	KLEMME 4-LEITER 2,5QMM GELB/GRÜN	BINDER 4 CONDUCTORS 2,5QMM YELLOW/GREEN	MORSETTIERA 4 CONDUTTORI 2,5QMM GIALLO / VERDE
5	* 0145013	FEINSICHERUNG 4A MITTELTRÄGE 5 X 20	FINE-WIRE FUSE 4A TIME LAGGED 5 X 20	FUSIBILE FINE 4A AZIONE RITARDATA 5 X 20
5	* 0145000	FEINSICHERUNG 10A MITTELTRÄGE 5 X 20	FINE-WIRE FUSE 10A TIME LAGGED 5 X 20	FUSIBILE FINE 10A AZIONE RITARDATA 5 X 20
6	0153054	SICHERUNGSKLEMME	SAFETY CLAMP	MORSETTIERA DI SICUREZZA
7	* 0135200	SCHÜTZ B6-30-10 230 V 40/60 HZ	CONTACTOR B6-30-10 230 V 40/60 HZ	CONTATTATORE B6-30-10 230 V 40/60 HZ
7	* 0135209	SCHÜTZ B6-30-01 230 V 40/60 HZ	CONTACTOR B6-30-01 230 V 40/60 HZ	CONTATTATORE B6-30-01 230 V 40/60 HZ
8	* 9520025	SCHÜTZ A9-30-01 230 V 50/60 HZ	CONTACTOR A9-30-01 230 V 50/60 HZ	CONTATTATORE A9-30-01 230 V 50/60 HZ
8	* 9520024	SCHÜTZ A12-30-01 230 V 50/60 HZ	CONTACTOR A12-30-01 230 V 50/60 HZ	CONTATTATORE A12-30-01 230 V 50/60 HZ

13.13 BAUGRUPPEN / EINZELTEILE

13.13 COMPONENT BLOCKS / PARTS

13.13 BLOCCHI DI COMPONENTI / PEZZI SINGOLI



EcoStar545 D
01.02.2002/FH

POS	IDENT. NR. IDENT. NO.	BEZEICHNUNG	DESIGNATION	DESCRIZIONE
	8004127	HAUBE KPL.	HOOD COMPL.	CAPPA COMPL.
	0463052	HAUBENFÜHRUNG RECHTS	HOOD ROD RIGHT HAND SIDE	GUIDA DESTRA PER CAPPA
	0463053	HAUBENFÜHRUNG LINKS	HOOD ROD LEFT HAND SIDE	GUIDA SINISTRA PER CAPPA
	8004149	KORBTRÄGER KPL.	BASKET GUIDE RAIL COMPL.	GUIDA D'APPOGGIO COMPL. PER CESTELLO
	8004406	TANKSIEB LINKS	TANK SIEVE LEFT HAND SIDE	FILTRO VASCA SINISTRO
	0251102	TANKSIEB RECHTS	TANK SIEVE RIGHT HAND SIDE	FILTRO VASCA DESTRO
	8004467	SCHLIEßBLECH LINKS	STRIKE PLATE	LAMIERA DI CHIUSURA
	8004141	SEITENVERKLEIDUNG	SIDE CLADDING	RIVESTIMENTO LATERALE
	8004142	FRONTVERKLEIDUNG	FRONT CLADDING	RIVESTIMENTO FRONTALE
	8004137	FEDERKASTENABDECKUNG	SPRING HOUSING COVER	RIVESTIMENTO CASSETTA MOLLE
	8004156	RÜCKWAND KPL.	REAR CLADDING COMPL.	RIVESTIMENTO SCHIENALE COMPL.
	0620455	ABSTANDHALTER FÜR VERKLEIDUNGEN	SPACER FOR CLADDING	DISTANZIATORI PER RIVESTIMENTO
	9500378	TISCHSTOLLEN KPL.	TABLE LEGS CPL.	PIEDINO K 220/221
	0495440	UNIVERSALKORB VKV 50/1	UNIVERSAL BASKET VKV 50/1	CESTELLO UNIVERSALE VKV 50/1
	0495445	KLEINTEILEKORB VKV 50/2	BASKET FOR SMALL PIECES VKV 50/2	CESTELLO PER PEZZI PICCOLI VKV 50/2
	0640040	PANZERSCHLAUCH 1/2" X 2000	REINFORCED HOSE 1/2" X 2000	FLESSIBILE RINFORZATO 1/2" X 2000
	9500011	PANZERSCHLAUCH 1/2" X 2000 WRC ZULASSUNG	REINFORCED HOSE 1/2" X 2000 WRC-APPROVED	FLESSIBILE RINFORZATO 1/2" X 2000 CERTIFICATO WRC

14.08 HAUBENGESTÄNGE

14.08 HOOD ROD

14.08 TUBATURA DELLA CAPOTE



Hg14_8.doc
01.12.2002/BP



14.08 HAUBENGESTÄNGE

14.08 HOOD ROD

14.08 TUBATURA DELLA CAPOTE



Hg14_8.doc
01.12.2002/BP

POS	IDENT. NR. IDENT. NO.	BEZEICHNUNG	DESIGNATION	DESCRIZIONE
1	0251103	HAUBENGESTÄNGE DV 80 T	HOOD ROD DV 80 T	TUBATURA DELLA CAPOTE DV80T
2	0620449	LAGERUNG FÜR HAUBEN- GESTÄNGE	HOOD ROD BEARING	CUSCINETTO PER TUBATURA DELLA CAPPA
3	8004480	DECKEL FÜR HAUBENROLLE	HOOD ROLLER COVER	COPERCHIO PER RULLO DI GUIDA
4	8000220	ROLLENBOLZEN SW 17 X 51 - M 8	ROLLER BOLT SW 17 X 51 - M 8	BULLONE PER RULLO SW 17 X 51 - M 8
5	0620451	HAUBENROLLE K 409	HOOD ROLLER K 409	RULLO DI GUIDA-CAPPA K 409
6	0340006	U-SCHEIBE 8,4 X 18 X 2	FRONT DISC 8,4 X 18 X 2	RONDELLA 8,4 X 18 X 2
7	0337005	HUTMUTTER SELBST- SICHERND, M 8	CAP NUT SELFLOCKING M 8	DADO A CAPPELLO AUTOBLOCCANTE, M 8
8	8004147	SPANNMUTTER M 8	TENSION NUT M 8	DADO A TENSIONE M 8
9	* 8004425	SPANNSCHRAUBE M 8 760 LANG	TENSION SCREW M 8 760 LONG	VITE DI TENSIONE M 8 760 LONG
10	* 0430006	ZUGFEDER 372 X 46,5 X 6,5	TENSION SPRING 372 X 46,5 X 6,5	MOLLA DI TRAZIONE 372 X 46,5 X 6,5
11	0620445	GLEITLAGER FEDERAUF- HÄNGUNG K 399	SLIDING BEARING FOR SPRING SUSPENSION K 399	CUSCINETTO AGGANCIAMENTO MOLLE. K 399
12	8004144	FEDERAUFHÄNGUNG OBEN	UPPER SPRING SUSPENDER	AGGANCIAMENTO PER MOLLE SUPERIORE
13	9541450	LINSENSCHRAUBE	OVAL HEAT SCREW	VITE CON TESTA A GOCCIA DI SEGO
14	9541531	O-RING 6X2	O-RING 6X2	ANELLO O-RING
15	0340005	U-SCHEIBE 10,5 X 18 X 1,6	FRONT DISC 10,5 X 18 X 1,6	RONDELLA 10,5 X 18 X 1,6
16	0335043	SECHSKANTMUTTER	HEXAGON NUT	DADO ESAGONALE

16.01 EINBAUWASSERENTHÄRTER

16.01 INCORPORATED SOFTENER

16.01 ADDOLCITORE ACQUA INCORPORATO



Ew16_1a.doc
01.06.98/FUS

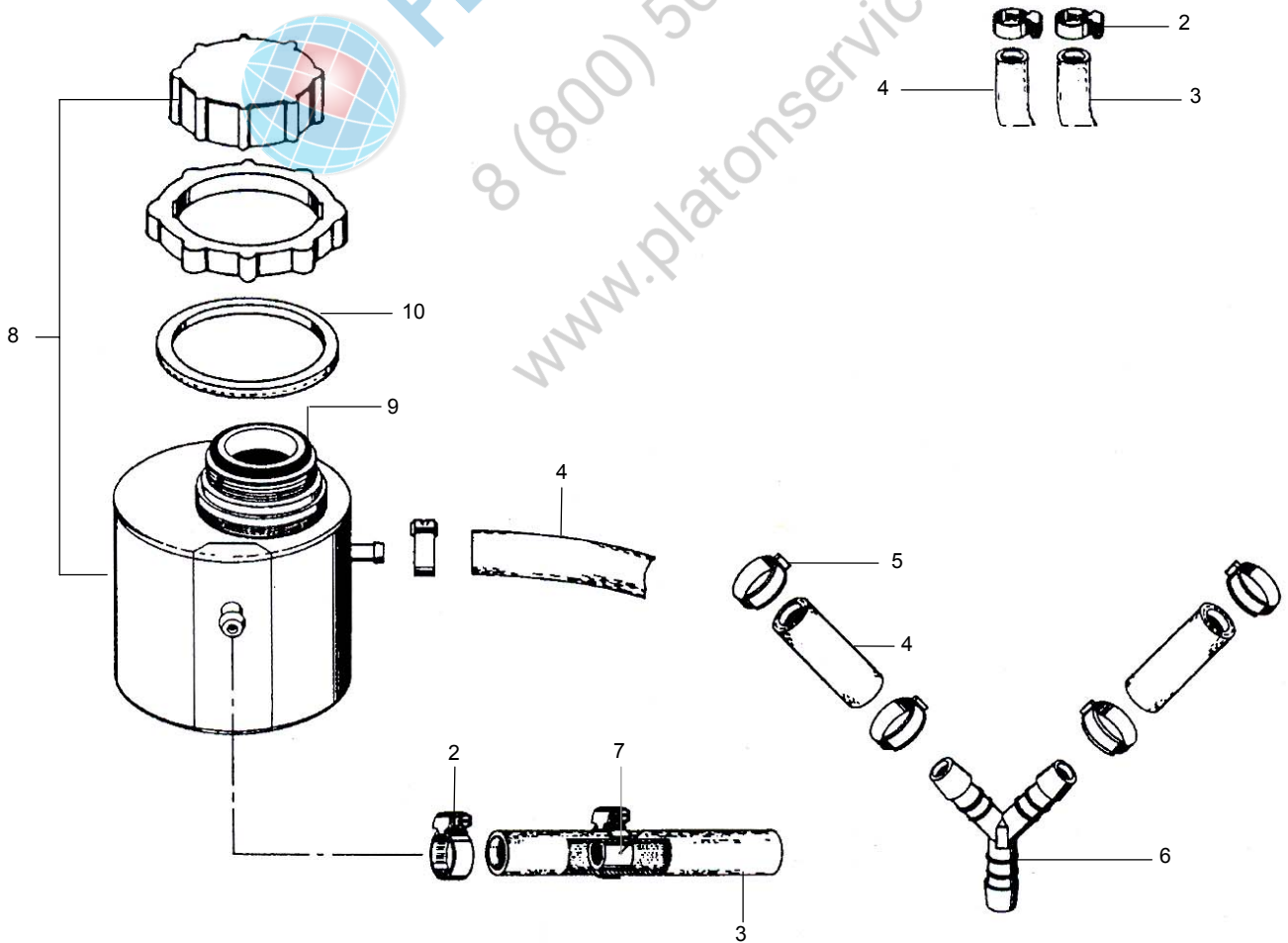
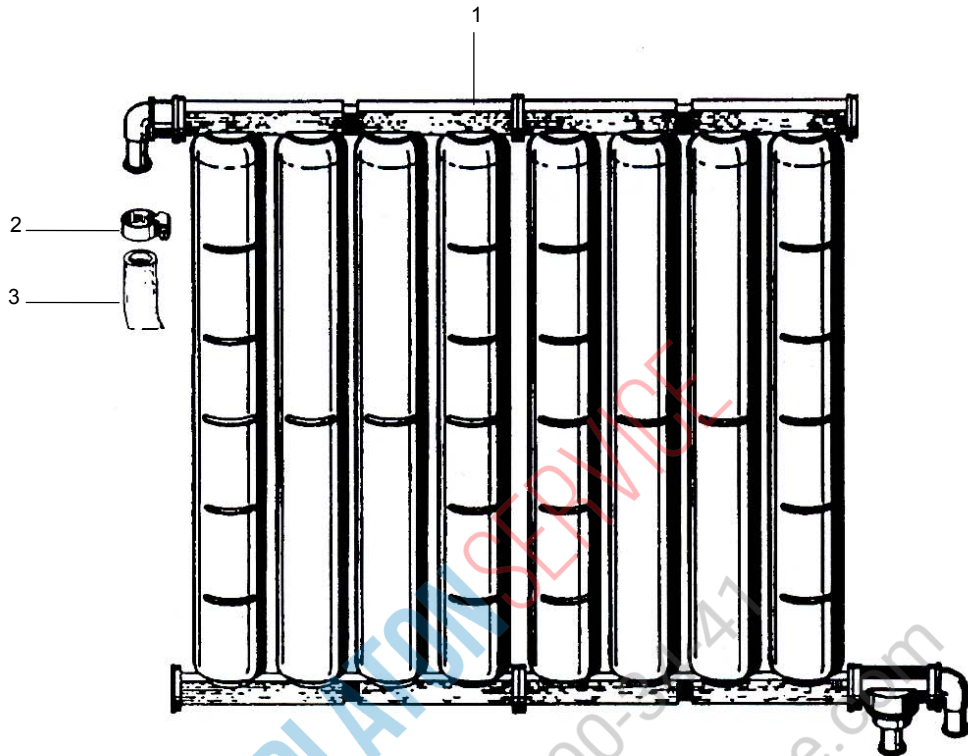

16.01 EINBAUWASSERENTHÄRTER

16.01 INCORPORATED SOFTENER

16.01 ADDOLCITORE ACQUA INCORPORATO



Ew16_1a.doc
01.06.98/FUS

POS	IDENT. NR. IDENT. NO.	BEZEICHNUNG	DESIGNATION	DESCRIZIONE
1	0270065	BASENAUSTAUSCHER EW 5, 8 ZYLINDER FV/OR/ECOSTAR 530F	SOFTENER EW 5, 8 CYLINDERS FV/OR/ECOSTAR 530F	ADDOLCITORE EW 5, 8 CILINDRI, FV/OR/ECOSTAR 530F
	0270063	BASENAUSTAUSCHER EW 5, 8 ZYLINDER, DV/ECOSTAR 545D	SOFTENER EW 5, 8 CYLINDERS, DV/ECOSTAR 545D	ADDOLCITORE EW 5, 8 CILINDRI, DV/ECOSTAR 545D
	0270064	BASENAUSTAUSCHER EW 2,5, 4 ZYLINDER, FV25/30/FR30	SOFTENER EW 2,5, 4 CYLINDERS, FV25/30/FR30	ADDOLCITORE EW 2,5, 4 CILINDRI, FV25/30/FR30
2	0233037	SCHLAUCHKLEMME 16 - 27	HOSE CLAMP 16 - 27	COLLARE 16 -27
3	9608600	SCHLAUCH 1/2"	HOSE 1/2"	FLESSIBILE 1/2"
4	9608607	SCHLAUCH 3/8"	HOSE 3/8"	FLESSIBILE 3/8"
5	0233077	1-OHR-KLEMME	1-EAR CLAMP	COLLARE AD UN ORECCHIO
6	0621040	Y-STÜCK YS 10	Y-PIECE YS 10	PEZZO Y - YS 10
7	9546133	MENGENREGLER KPL.	FLOW CONTROL DEVICE COMPL.	FLUSSOMETRO CPL.
8	* 0270106	SALZLÖSEBEHÄLTER	SALT DISSOLVING CONTAINER	CONTENITORE DISSOLUZIONE SALE
9	* 0270107	O-RING 39 X 4	O-RING 39 X 4	ANELLO O-RING 39 X 4
10	9500825	FLACHDICHTUNG	FLAT PACKING	GUARNIZIONE PIATTA
	0270104	FÜHRUNGSRING	GUIDING RING	ANELLO PER GUIDA
	8005092	VERDREHSICHERUNG	TWIST PROTECTION	PROTEZIONE ANTIROTAZIONE
	0265020	TRICHTER	FUNNEL	IMBUTO



PLATON SERVICE
8 (800) 500-24-47

www.platonservice.com

17.05 REINIGERDOSIERUNG

17.05 DETERGENT DOSING UNIT

17.05 DOSATORE DEL DETERGENTE



Rd17_5a.doc
01.12.2000/FH

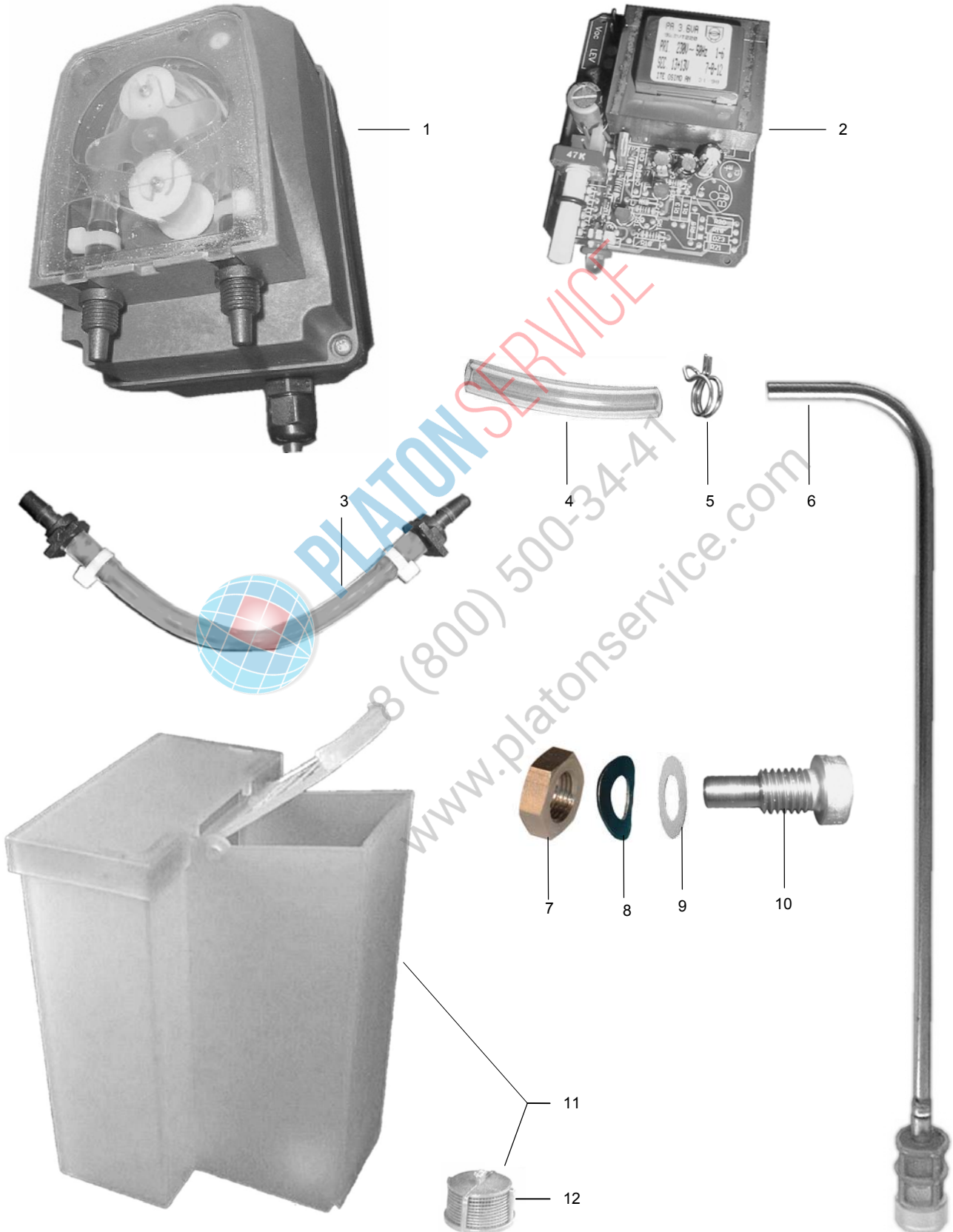

17.05 REINIGERDOSIERUNG

17.05 DETERGENT DOSING UNIT

17.05 DOSATORE DEL DETERGENTE



Rd17_5a.doc
01.12.2000/FH

POS	IDENT. NR. IDENT. NO.	BEZEICHNUNG	DESIGNATION	DESCRIZIONE
1	* 9511667	REINIGERDOSIERGERÄT PR7, 230V 50HZ	DETERGENT DOSING UNIT PR7, 230V 50HZ	DOSATORE DEL DETERGENTE PR7, 230V 50HZ
2	9505653	DREHZAHLREGELUNG	SPEED CONTROL	REGOLAZIONE GIRI
3	* 9511675	DOSIERSCHLAUCH 7 L/H SANTOPRENE	DOSING HOSE 7 L/H SANTOPRENE	FLESSIBILE PER DOSARE 7 L/H SANTOPRENE
4	* 0260007	SCHLAUCH KLARSICHT 6 X 1,5	HOSE TRANSPARENT 6 X 1,5	FLESSIBILE TRASPARENTE 6 X 1,5
5	* 9500045	DRAHTSCHLAUCHKLEMME 8,8 - 9,3 MM	HOSE WIRE CLAMP 8,8 - 9,3 MM	COLLARE 8,8 - 9,3 MM
6	8005393	ANSAUGROHR, 340 MM	SUCTION TUBE, 340 MM	TUBO D'ASPIRAZIONE, 340 MM
6	8005372	ANSAUGROHR, 420 MM	SUCTION TUBE, 420 MM	TUBO D'ASPIRAZIONE,, 420 MM
7	0335019	SECHSKANTMUTTER DIN 934 - M10	HEXAGON NUT DIN 934 - M10	DADO ESAGONALE DIN 934 - M10
8	9603790	FEDERSCHEIBE M10	SPRING WASHERV M10	RONDELLA A MOLLA
9	* 9603787	FLACHDICHTUNG 10X16X2	FLAT PACKING 10X16X2	GUARNIZIONE PIATTA 10X16X2
10	8000013	SCHLAUCHANSCHLUß	HOSE CONNECTION	COLLEGAMENTO FLESSIBILE
11	8004424	REINIGERBEHÄLTER K 376	DETERGENT CONTAINER K 376	RECIPIENTE PER DETERGENTE
12	0113098	MAGNETVENTILFILTERSIEB	FILTER FOR SOLENOID VALVE	FILTRO PER ELETTROVALVOLA



8 (800) 500-3447
www.platonservice.com